

VICTORIAN type 50 lighting pole

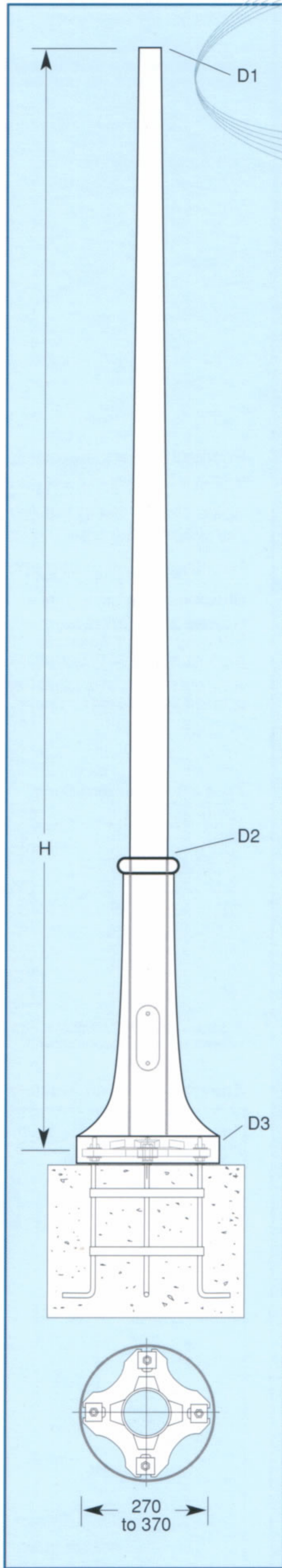

DESIGNERS AND MANUFACTURERS OF
URBAN STREETWARE AND LIGHTPOLES

GOLDSPAR

Ideal for parks and gardens in a more classical style, the Victorian lighting pole is also well-suited to such old-established areas as the Rocks area of Sydney or the Quays of Hobart.

The Victorian pole comprises a cast aluminium base with spun tapered aluminium top.

The pole has a base plate mounting system with rag bolts set in concrete.

Access to hatch is gained by lifting the base casting after unscrewing a grub screw.

Structural note:

Goldspar tapered aluminium light poles are manufactured to comply with Australian Standards (AS1170.2 -1989) from high quality 6000 Series aluminium tube.

All poles have structural engineering certification for above ground structures.

Type 50 - specifications

Code	H	D1	D2	D3
50/3.7	3700	76	150	360
50/4.2	4200	76	150	360
50/5	5000	76	150	360

Average depth for footing is 1/10th pole height (consult your structural engineer).

Standard screwed hatches

